



x|act i

Precision Pressure Transmitter for Food Industry, Pharmacy and Biotechnology

- ▶ with integrated display and operating module
- ▶ hygienic version
- ▶ flush welded diaphragm
- ▶ nominal pressure ranges from 0 ... 350 mbar up to 0 ... 35 bar

DESIGN

Our piezoresistive silicon sensor DSP 111 is the basis for our x|act i. The sensor is – together with digital compensation electronics – directly mounted into the pressure port, and is connected to the intelligent display and operating module via a I²C-interface of the compensation electronics. With the help of this innovative housing concept, precise and long-term stable pressure transmitters with flush-welded diaphragm and low thermal error can be produced.

OPERATING

The display and operating module allows an on-site setting of all x|act i functions, which can be easily and quickly parametrized via tree buttons:

- offset and span
- damping
- units
- display
- password

The device can be optionally equipped with HART® communication, and will then be delivered together with the appropriate configuration software (against additional charge).

- ▶ accuracy:
0.05 % FSO BFSL
(0.1 FSO IEC 60770)
- ▶ turn-down 1:10
- ▶ several process connections:
 - G1" cone
 - clamp
 - dairy pipe
 - Varivent®
 - flange
 - DRD
- ▶ high ingress protection IP 67
- ▶ optionally:
 - **HART®-communication**
 - **Ex-intrinsically safe version (zone 0)**
 - **cooling element for media temperatures up to 300 °C**
 - PROFIBUS PA
(in preparation)

Characteristics

x|act i
Precision Pressure Transmitter



Pressure ranges¹						
Nominal pressure gauge [bar]	0.35	1	2	7	17	35
Nominal pressure abs. [bar]	-	1	2	7	17	35
Permissible overpressure [bar]	1	3	6	20	60	100
¹ higher pressure ranges on request; on demand we adjust the devices by software on the required pressure ranges, within the turn-down-possibility (gauge starting at 0.1 bar, abs. starting at 0.35 bar)						
Vacuum ranges						
Nominal pressure gauge [bar]	-0.17 ... 0.17	-0.35 ... 0.35	-1 ... 1	-1 ... 2	-1 ... 7	
Permissible overpressure [bar]	0.5	1	3	6	20	
Output signal / Supply						
Standard	2-wire: 4 ... 20 mA / $V_s = 10 \dots 30 V_{DC}$					
Option	2-wire: 4 ... 20 mA / $V_s = 10 \dots 28 V_{DC}$					
Ex-protection	2-wire: 4 ... 20 mA with HART [®] communication / $V_s = 10 \dots 28 V_{DC}$					
Ex-protection/ HART [®]	digital output signal (according to IEC 61158) / $V_s = 10 \dots 30 V_{DC}$ (in preparation)					
PROFIBUS PA						
Current consumption	max. 25 mA					
Performance						
Accuracy ^{2,3}	turn-down $\leq 1:5$ $\leq \pm 0.1$ % FSO turn-down $> 1:5$ $\leq \pm [0.1 + 0.015 \times \text{turn-down}]$ % FSO with turn-down = nominal pressure range / adjusted range					
Permissible load	$R_{max} = [(V_s - V_{s,min}) / 0.02] \Omega$			load during HART [®] communication: $R_{min} = 250 \Omega$		
Influence effects	supply: 0.05 % FSO / 10 V			permissible load: 0.05 % FSO / k Ω		
Long term stability	$\leq \pm (0.1 \times \text{turn-down})$ % FSO / year					
Response time	200 ms – without consideration of electronic damping			measuring rate 5/sec		
Adjustability	electronic damping: 0 ... 100 sec offset: 0 ... 90 % FSO turn-down of span: max. $1:10^4$					
² accuracy according to IEC 60770 – limit point adjustment (non-linearity, hysteresis, repeatability)						
³ for nominal pressure ranges ≤ 0.35 bar the accuracy is calculated as follows: $\leq \pm [0.1 + 0.02 \times \text{turn-down}]$ % FSO						
⁴ span minimal 0.1 bar (gauge) or 0.35 bar (absolute); turn-down with 35 bar maximal 1:2						
Thermal errors / Permissible temperatures						
Thermal error ⁵	$\leq \pm (0.1 \times \text{turn-down})$ % FSO / 10 K in compensated range -20 ... 80 °C					
Permissible temperatures ⁶	medium: -40 ... 125 °C		environment: -20 ... 70 °C		storage: -30 ... 80 °C	
⁵ an optional cooling element can influence thermal effects for offset and span depending on installation position and filling conditions						
⁶ for vacuum ranges and absolute pressure the max. medium temperature is 70 °C; max. temperature of the medium for nominal pressure gauge > 0 bar: 150 °C for 30 minutes with a max. environmental temperature of 50 °C (without cooling element); with optional cooling element its maximum permissible temperature is valid						
Electrical protection						
Short-circuit protection	permanent					
Reverse polarity protection	no damage, but also no function					
Electromagnetic compatibility	emission and immunity according to EN 61326					
Mechanical stability						
Vibration	5 g RMS (20 ... 2000 Hz)					
Shock	100 g / 11 ms					
Materials / Filling fluids						
Pressure port	Varivent [®] , dairy pipe und clamp: stainless steel 1.4435 (316L) G1" cone, DRD and flange: stainless steel 1.4571 (316Ti)					
Housing	stainless steel 1.4301 (304)					
Viewing glass	laminated safety glass					
Seals (media wetted)	none, not included in the scope of delivery					
Diaphragm	stainless steel 1.4435 (316 L) options: Hastelloy [®] , Tantal (possible from 1 bar); others on request					
Media wetted parts	pressure port, diaphragm, seal (if existing)					
Filling fluids	standard: silicon oil options: food compatible oil (with FDA approval); Halocarbon and others on request					

Explosion protection (optionally)	
Approval AX12-x act i	zone 0: II 1 G EEx ia IIC T4
Safety technical maximum values	$U_i = 28 \text{ V}$, $I_i = 93 \text{ mA}$, $P_i = 660 \text{ mW}$
Permissible temperatures for environment	in zone 0: -20 ... 60 °C with p_{atm} 0.8 bar up to 1.1 bar in zone 1: -20 ... 70 °C
Connecting cables (by factory)	capacitance: signal line/shield also signal line/signal line: 160 pF/m inductance: signal line/shield also signal line/signal line: 1 µH/m
Miscellaneous	
Display	LC display, visible range 32.5 x 22.5 mm; 5-digit 7-segment main display, digit height 8 mm, range of indication ±9999; 8-digit 14-segment additional display, digit height 5 mm; 52-segement bargraph; accuracy 0.1% ± 1 digit
Ingress protection	IP 67
Installation position	any (standard calibration in a vertical position with the pressure port connection down; differing installation position have to be specified in the order)
Weight	min. 400 g (depending on mechanical connection)
Operational life	> 100 x 10 ⁶ pressure cycles

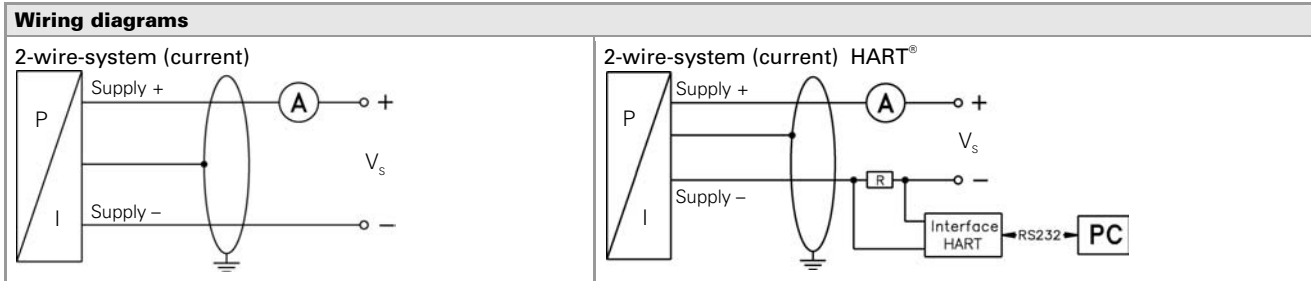

Pin configuration		
Electrical connections	M12x1 (4-pin)	cable colour (DIN 47100)
Supply +	1	white
Supply -	3	brown
Ground	plug housing	yellow / green (shield)

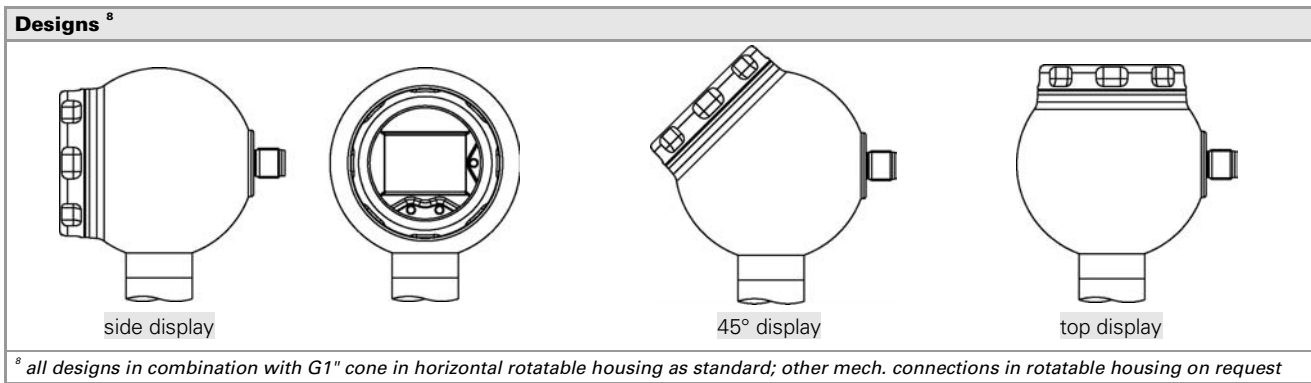
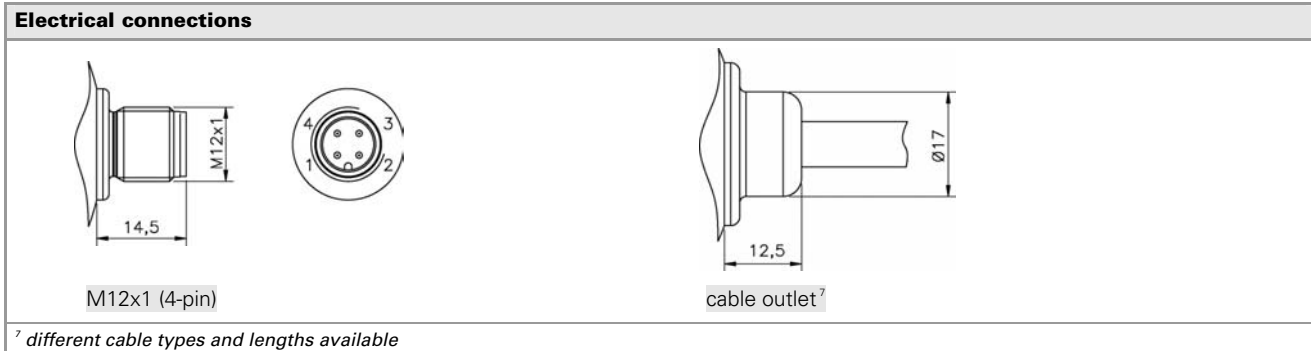

Dimensions (in mm)

G1" cone

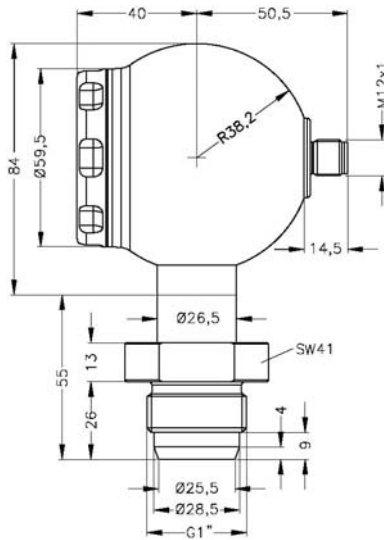

Clamp (ISO 2852)

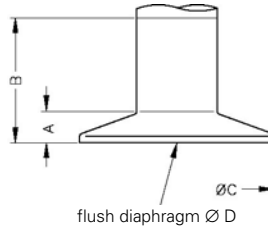

dimensions in mm			
size	1"	1 1/2"	2"
A	11	11	22
B	41	41	22
C	50.5	50.5	64
D	24	32	45

Dairy pipe⁹ (DIN 11851)

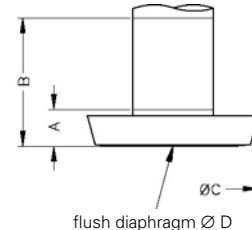

dimensions in mm			
size	DN 25	DN 40	DN 50
A	14	23	23.5
B	44	23	23.5
C	44	56	68.5
D	24	32	45

Varivent[®]

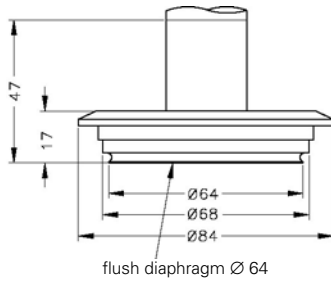

DN 40/50

Flange¹⁰ (DIN 2501)

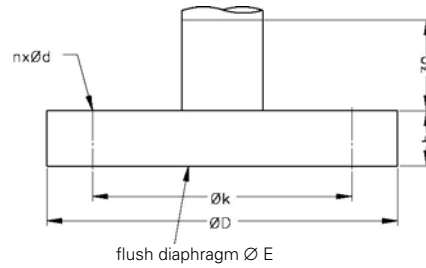

dimensions in mm			
size	DN25/PN40	DN50/PN40	DN80/PN16
D	115	165	200
E	30	89	89
k	85	125	160
b	18	20	20
n	4	4	8
d	14	18	18

DRD⁹

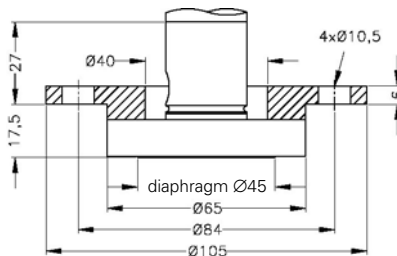

Cooling element

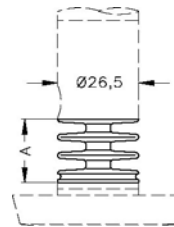

temperature range	150° C	300° C
size A	22	34
number of cooling fins	2	3

⁹ cup nut resp. mounting flange is included in the delivery (already pre-assembled)

¹⁰ DN80/PN16 possible for nominal pressure ranges $P_N \leq 7$ bar

HART[®] is a registered trade mark of HART Communication Foundation; Hastelloy[®] is a trademark of Haynes International Inc.; Varivent[®] is a trademark of GEA Tuchenhagen GmbH; Windows[®] is a registered trade mark of Microsoft Corporation

